

# CCS Technical Documentation

## NPM-2NX Series Transceivers

# Service Tools

## Contents

	Page No
Docking Station (JBV-1) and Docking Station Adapter (MJF-1) .....	5
Product Code .....	5
View of Docking Station .....	5
View of Docking Station Adapter .....	5
Galvanic Contact (GAC-2) .....	6
Product Code .....	6
View of Galvanic Contact .....	6
Flash Adapter (FLA-14).....	7
Product Code .....	7
View of Flash Adapter .....	7
Soldering Jig (MJS-26) .....	8
Product Code .....	8
View of Soldering Jig .....	8
Flash Prommer (FPS-8) .....	9
Product Code .....	9
View of Flash Prommer .....	9
Audio Cable (ADS-6) .....	10
Product Code .....	10
View of Audio Cable .....	10
Audio box (JBA-8).....	11
Product Code .....	11
View of Audio Box .....	11
Mbus/Fbus Cable (XCS-4).....	12
Product Code .....	12
View of Mbus/Fbus Cable.....	12
DC Cable (SCB-3) .....	13
Product Code .....	13
View of DC Cable .....	13
Power Cable (PCS-1) .....	14
Product Code .....	14
View of Power Cable .....	14
RF Cable (XRF-1).....	15
Product Code .....	15
View of RF Cable.....	15
SW Security Device (PKD-1) .....	16
Product Code .....	16
View of SW Security Device .....	16
Power Pack (DDC-10) .....	17
Product Code .....	17
View of Power Pack .....	17
Module Jig (MJS-17) .....	18
Product Code .....	18
View of Module Jig .....	18
Parallel Flash Prommer (FPS-8C).....	19
Product Code .....	19
View of Parallel Flash Prommer .....	19
POS Flash (FLS-4).....	20

Product Code .....	20
View of POS Flash Adapter .....	20
MBUS Cable (DAU-9P) .....	21
Product Code .....	21
View of MBUS Cable DAU-9P .....	21
MBUS Cable (DAU-9S) .....	22
Product Code .....	22
View of MBUS Cable DAU-9S .....	22
Printer Cable (AXP-8) .....	23
Product Code .....	23
View of Printer Cable .....	23
Modular T-adapter .....	24
Product Code .....	24
View of Modular T-adapter .....	24
Gait Test SIM card .....	25
Product Code .....	25
Module Jig MJS-17 0770353 .....	26
Introduction .....	26
List of modules .....	26
Technical Specifications .....	26
Electrical characteristics .....	26
Testing .....	27
Recommended Test Equipment .....	27
Test Procedure .....	27
User Instructions .....	27
General instruction .....	27
Operation .....	27
Over current and voltage .....	27
Assembly .....	28
Construction .....	28
Changeable parts .....	28
Modifications of MJS-17 for NPM-2NX .....	29
Change of Alignment pins .....	29
SIM Module pwb .....	30
Changing the test pins .....	30
Pulling the test pins out of pwb .....	30
Docking Station Adapter MJF-1 0770354 .....	31
Introduction .....	31
List of Modules .....	31
Technical Specifications .....	31
DC Characteristics .....	31
D- Connector signals .....	31
Mechanical Characteristics .....	33
Environmental Conditions .....	33
Temperature Conditions .....	33
Testing .....	33
Recommended Test Equipment .....	33
Test Procedure .....	33

User Instructions .....	34
General instruction .....	34
Operation .....	34
Over current and voltage .....	34
Assembly .....	34
Construction .....	34
Changing the test pins to MJF-1 .....	34
Flash Adapter FLA-14 0080538 .....	36
Introduction .....	36
List of Modules .....	36
Technical Specifications .....	36
DC Characteristics.....	36
Modes of operation.....	36
Mechanical Characteristics .....	37
Environmental Conditions .....	37
Temperature Conditions .....	37
Functional Description .....	37
Circuit Description .....	37
Testing .....	37
Recommended Test Equipment .....	37
Test Procedure.....	38
User Instructions .....	38
General instruction .....	38
Operation .....	38
Assembly .....	38
Construction .....	38
Changing the test pins to FLA-14 .....	38

## Docking Station (JBV-1) and Docking Station Adapter (MJF-1)

The Docking Station and the Docking Station Adapter are needed for Mbus, Fbus, RF, and audio connections.

This setup allows connection between flash prommers. When the audio box is connected, it has to be connected to the phone's audio connector. The Docking Station can be powered by FPS-8 or external power supply.

### Product Code

Docking Station JBV-1	0770298
Docking Station Adapter MJF-1	0770354

### View of Docking Station



### View of Docking Station Adapter



## Galvanic Contact (GAC-2)

Galvanic Contact GAC-2 adapter provides an RF galvanic connection to RF test and measuring equipment.

### Product Code

Galvanic Contact GAC-2

0770379

### View of Galvanic Contact



## Flash Adapter (FLA-14)

Flash Adapter allows continuous maximum power supply for the phone from an external power supply (ACP-8). The flash adapter allows Mbus/Fbus connections. The flash adapter is protected against over-voltage, over-current, and cross-connection. The flash adapter provides a regulated voltage to the phone.

*Note: The flash adapter is designed for flashing only.*

### Product Code

Flash Adapter FLA-14	0770293
with power cable	0080538

### View of Flash Adapter



## Soldering Jig (MJS-26)

The Soldering Jig is designed to hold PWB during repair and troubleshooting.

### Product Code

Soldering Jig MJS-26

0770352

### View of Soldering Jig

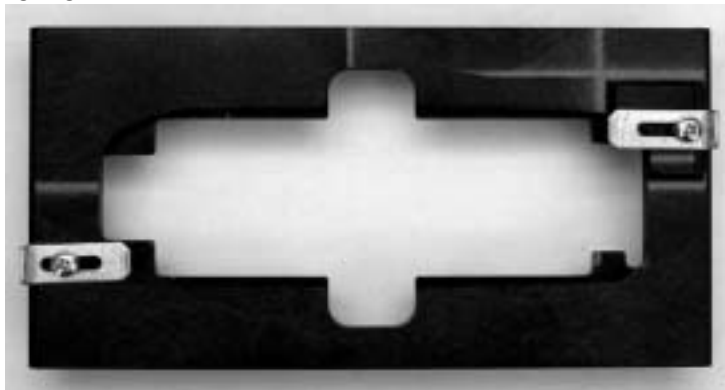



## Flash Prommer (FPS-8)

The Flash Prommer FPS-8 is used for heavy flash.

### Product Code

Flash Prommer FPS-8

0080321

### View of Flash Prommer



## Audio Cable (ADS-6)

The Audio Cable connects to the Audio Box JBA-8.

### Product Code

Audio Cable ADS-6

0730241

### View of Audio Cable



## Audio box (JBA-8)

The JBA-8 is required for audio testing.

### Product Code

Audio Box JBA-8

0770320

### View of Audio Box



## Mbus/Fbus Cable (XCS-4)

The XCS-4 Service Cable is a modular cable for flashing DCT4 products.

### Product Code

Mbus/Fbus Cable XCS-4

0730178

### View of Mbus/Fbus Cable



## DC Cable (SCB-3)

The DC Cable SCB-3 is used to connect the docking station to the charger connection (Vin) of the phone to conduct the charger calibration service procedure.

### Product Code

DC Cable SCB-3

0730114

### View of DC Cable



## Power Cable (PCS-1)

The Power Cable PCS-1 is used to connect the service tools (JBV-1, MJS-17) to an external power supply.

### Product Code

Power Cable PCS-1                      0730012

### View of Power Cable



## RF Cable (XRF-1)

RF Cable XRF-1 is used to connect the service tools to RF measuring equipment.

### Product Code

RF Cable XRF-1

0730085

### View of RF Cable



## SW Security Device (PKD-1)

SW security device PKD-1 is hardware device that, when connected to the parallel (LPT) port of the PC, enables the use of the service software. Without the dongle present, it is not possible to use the service software. Printers or other peripheral devices can be connected to the PC through the dongle, if needed.

*Caution: Make sure that you have switched off the PC and the printer before making connections!*

*Caution: Do not connect the PKD-1 to the serial port. You may damage your PKD-1!*

### Product Code

SW Security Device PKD-1                      0750018

### View of SW Security Device





## Power Pack (DDC-10)

The Power Pack is designed to provide the phone with power via the FLA-14. The phone's own battery can be used in the DDC-10.

*Note: DDC-10 allows battery charging. When it is used as a charger, the power pack need to be disconnected.*

*Note: When DDC-10 is used as a Power Pack, battery charging is not allowed!*

### Product Code

Power Pack DDC-10 0670405

### View of Power Pack

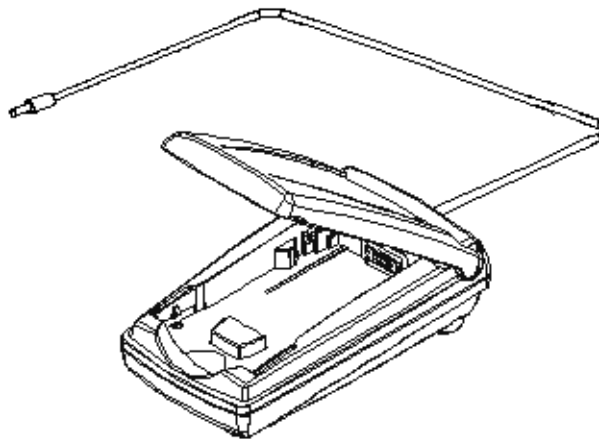

*Note: Do not plug cable into the charger receptacle.*

## Module Jig (MJS-17)

This jig allows phone PWB level service and troubleshooting.

### Product Code

Module Jig MJS-17

0770353

### View of Module Jig



## Parallel Flash Prommer (FPS-8C)

The FPS-8C Flash Prommer is used for heavy parallel flashing.

### Product Code

Parallel Flash Prommer FPS-8C      0080396

### View of Parallel Flash Prommer



## POS Flash (FLS-4)

The Point of Sale (POS) flash is a low-cost software upgrade tool. This requires the XCS-1 cable and ACP-8U for operation.

### Product Code

POS Flash Adapter FLS-4	0774263
FLS-4S Sales Package for Americas	0080543
APAC	0080542
Europe/Africa	0080541

### View of POS Flash Adapter



## MBUS Cable (DAU-9P)

The MBUS cable DAU-9P provides a connection from the serial port of the computer to the system connector of the phone.

### Product Code

MBUS Cable DAU-9P

0272034

### View of MBUS Cable DAU-9P



## MBUS Cable (DAU-9S)

The MBUS Cable DAU-9S has a modular connector and is used with the service Audio Box JBA-8.

### Product Code

MBUS Cable DAU-9S

0730108

### View of MBUS Cable DAU-9S



## Printer Cable (AXP-8)

The Parallel Printer Cable connects the parallel connector of the PC and the parallel input of the FPS-8 or FPS-8C.

### Product Code

Printer Cable AXP-8

073F000

### View of Printer Cable



## Modular T-adapter

The Modular T-adapter is a suitable branching unit to provide the needed parallel modular connections.

### Product Code

Modular T-adapter 4626134

### View of Modular T-adapter

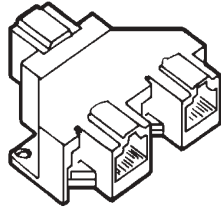



## Gait Test SIM card

Service point GAIT Test SIM to be used in connection with the NPM-2NX handset.

### Product Code

Gait Test SIM card *0750190*

### View of Gait Test SIM card



## Module Jig MJS-17 0770353

### Introduction

Module Jig MJS-17 is designed for regional Central Services for engine testing. It can be used for flashing and RF, battery, system, SIM reader. The MJS-17 sales pack includes all the needed modification parts for NPM-2NX. The MJS-17 is equipped with over current, over voltage and voltage polarity -protection.

### List of modules

Table 1: List of modules

Name of module	NMP code	Material code	Notes
Module service jig	MJS-17	0770353	Module service jig to R&D and testing environment

### Technical Specifications

#### Electrical characteristics

Table 2: Electrical ratings

Parameter	Min	Nom	Max	Notes
Supply voltage	3.0V		5.0V	Abs.Max.10V!
Vbatt	3.0V	3.9V	4.2V	
Vbat current			2.0A	
Vbat current	2A			
BTEMP Local mode Normal mode		560R 47k		switch 3
BSI Local mode Normal mode		560R 68k		switch2
BSI → FPS8 ON/OFF				switch1

Figure 1: Switches

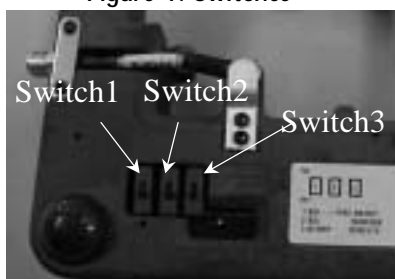

## Testing

### Recommended Test Equipment

- 1 Power supply
- 2 Scope
- 3 Multimeter
- 4 Network analyzer

### Test Procedure

- 1 Check visually that all mechanical parts are well placed and properly fixed together
- 2 Check that Vbatt-line wakes when supply voltage is 3.2 V  $\pm$ 2%
- 3 Check that Vbatt-line shuts down when supply voltage is 4.2 V  $\pm$ 2%
- 4 Measure XRS-2 RF-cable attenuation:
  - 900 MHz 0.2dB  $\pm$ 0.1dB
  - 1800 MHz 0.3dB  $\pm$ 0.1dB
  - 1900 MHz 0.4dB  $\pm$ 0.1dB

## User Instructions

### General instruction

*Note: MJS 17 is manufactured out of a very spaltible material, Trespa Athlon. DO NOT HANDLE ROUGHLY.*

*Warning: The absolute maximum supply voltage is 10 V (recommended 5V). Higher voltages will destroy the Module Jig.*

### Operation

- 1 Open module jig by pressing the button on the cover and lift the cover from the finger –cutting.
- 2 Put pcb engine through it's corner holes to alignment pins on the base of the module jig.
- 3 NOTE! PCB MUST BE SET TO IT'S PLACE FULLY DOWNRIGHT!
- 4 Close the module jig by pressing the cover until the lock "clicks".
- 5 Connect modular cable XMS-3 to modular connector of MJS 17.
- 6 Adjust supply voltage to 3.0 – 4.2 V.  
*Note: Before adjusting the power supply, make sure that the MJS-17 is connected to the ground.*
- 7 Connect DC –plug to DC –jack of MJS 17.
- 8 Connect RF –cable to RF-connector (item 7) of the MJS 17.
- 9 If used the pcb with lightguide and LCD –module, you can put the keymat film to it's position on the engine.
- 10 Use a probe to test the components of the engine.

### Over current and voltage

The *Module Jig* has overcurrent protection (2A fuse). Over current protection activates if the Vbatt-line is overloaded.

Do not use higher supply voltage than 5V. If absolute maximum supply voltage 10V is exceeded, tantalum capacitors in supply line (V+) will be damaged and *MJS 17* is permanently out of use.

## Assembly

### Construction

Figure 2: MJS-17 closed



Figure 3: Fuse, RF connector and SIM pwb

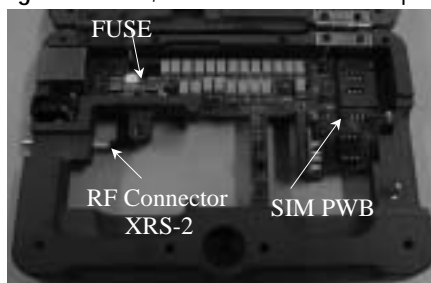

### Changeable parts

Table 3: Changeable electrical parts

Item	Qty	Reference	Value	Model	Description	NMP code	MFG
33	1	MEK1	T2A	Slow fuse	Fuse 5x20mm	na	Bussmann
35	11	MEK3- MEK12	1.5A	GKS-079301050A1300	Probe for KS-07935	ref (1)	Ingun

1) available only as 10 pcs sales pack 0770488

Table 4: Changeable mechanical parts

Item	Qty	Description	Drawing number	NMP code	Supplier
2	1	Alignment pin right	99EM005E	ref (2)	Oulun hienomek
3	1	Alignment pin left	99EM006D	ref (2)	Oulun hienomek
4	1	Alignment pin (MJS-17 L/C) right	1AZM001A	ref (2)	Oulun hienomek
5	1	Alignment pin (MJS-17 L/C) left	00NM003D	ref (2)	Oulun hienomek
	1	Sim module		ref (2)	PKC
7	1	XRS-2 RF connector MZ		0730182	Sorv-elektro

2) available as a kit only; MJS-17K spare part kit for MJS-17, code 0770495

### Modifications of MJS-17 for NPM-2NX

The sales package includes all the needed components for preparing the jig for NPM-2NX

Figure 4: Parts needed for NPM-2NX.

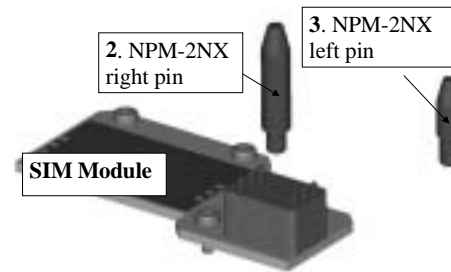

### Change of Alignment pins

Figure 5: Pin storage

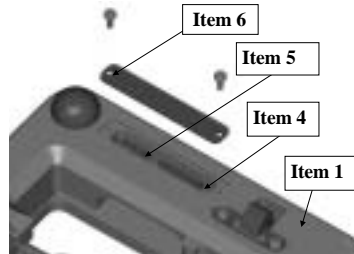

**Step 1:** Open two screws by torx screwdriver (tx6) behind in the bottom of the jig.

**Step 2:** Take aligning pins 4 and 5 out of slot.

**Step 3:** Unscrew aligning pins 2 and 3 carefully using pliers. Use thin board or rubber plate between pliers and aligning pins to avoid disturbing surface of the pins.

**Step 4:** Screw new aligning pins 4 and 5 (for NPW-2/NHP-2NX/NHP-2FX) to the same place using the same pliers.

*Note the order of the pins!*

Figure 6: Unscrewed aligning pins

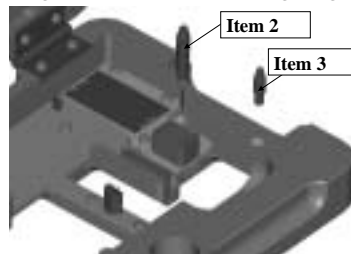

**Step 5:** After changing the pins, put NPM-2NX alignment pins (items 2 and 3) back to slot behind the Base, item 1.

### SIM Module pwb

**Step 1:** Screw three torx screws of SIM Module pcb and take the pcb out of MJS-17.

**Step 2:** Fix the pcb to its place in Cover (item 12).

Figure 7: Opened SIM Module pcb

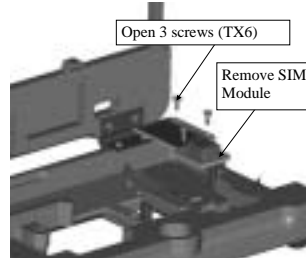
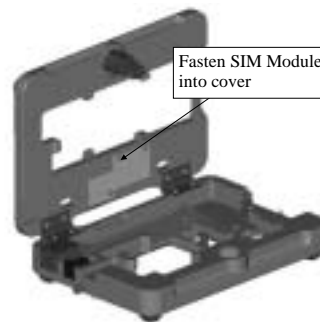

Figure 8: SIM Module stored in cover



### Changing the test pins

#### Pulling the test pins out of pwb

Pull the test pins out from pwb 1 by using thin sharpness pliers.

*Note: Make sure you take hold of the right place on the test pins. Do not take hold of the lowest part of the test pins to avoid disturbing the base of test pins.*

Figure 9: Changing the test pins



Figure 10: Contact with the test pin



## Docking Station Adapter MJF-1 0770354

### Introduction

The MJF-1 docking station adapter has been designed for Services for calibration and software update use. It is used with Docking station JBV-1. MJF-1 makes signal connections to the transceiver. The Docking station adapter MJF-1's main electronics functions are:

- Phone recognizing from BTEMP
- Filters of FBUS – signals

### List of Modules

Table 5: List of modules

Name of Module	NMP code	Material code	Notes
Docking station adapter	MJF-1	0770354	Docking station adapter to AMS usage

## Technical Specifications

### DC Characteristics

Table 6: Electrical ratings

Parameter	Min	Nom	Max
Recognizing voltage from BTEMP	0,108V	0,111V	0,114V

### D- Connector signals

D-connector (male) is between MJF-1 and JBV-1.

Figure 11: D-connector signals

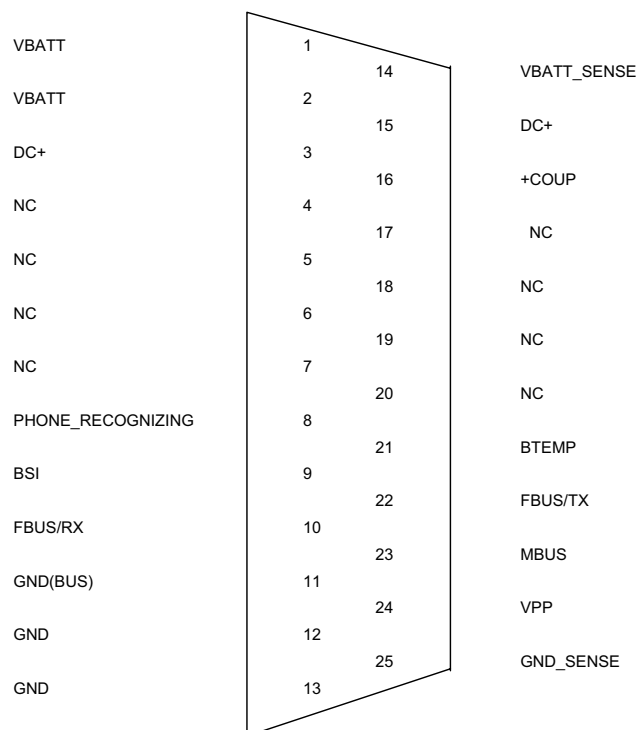

Table 7: D-connector signal description

PIN	Signal	Description	Min	Max
1,2	VBATT	Battery voltage to phone	3.0V / 0A	5.0V / 1.5A
2	VBATT			
3, 15	DC+	Supply voltage to JBV-1		
4	NC	Not connected		
5	NC	Not connected		
6	NC	Not connected	0	
7	NC	Not connected		
8	PHONE_RECOGNIZING	Phone recognizing from jig. Active low	0	+coup ( 3.3V)
9	BSI	BSI signal from phone		
10	FBUS/TX	FBUS TX signal from modular connector		
11	GND(BUS)	GND from modular connector. Not connected to battery GND on JBV-1		
12,13	GND	Battery voltage GND		
14	VBATT_SENSE	Battery voltage sense. Used for regulator voltage feedback		
16	+COUP	Coupler voltage	3.0V	3.3V
17	NC	Not connected		
18	NC	Not connected		



19	NC		
20	NC		
21	BTEMP	BTEMP signal from phone	
22	FBUS/RX	FBUS RX signal from modular connector	
23	MBUS	MBUS signal from modular connector	
24	VPP	VPP signal from modular connector	
25	GND_SENSE	Battery gnd sense Used for regulator voltage feedback	

### Mechanical Characteristics

Table 8: Mechanical characteristics

Unit	Dimensions (mm) (W x H x D)	Weight (g)	Material
MJF-1	71.5 x 36.8 x 119,6	150	ABS/PC, Cycloy C1000F Color. 76701 Black

Figure 12: MJF-1 main dimensions

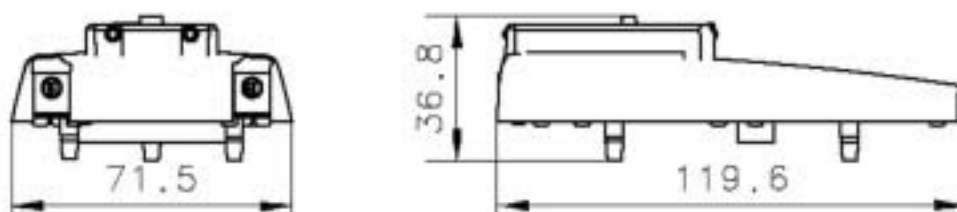

### Environmental Conditions

#### Temperature Conditions

Table 9: Allowed ambient temperatures

	Ambient Temperature (degrees Celcius)
Operating temperature	+5...+35
Storage temperature	-30...+60
Humidity RH	Max. 90%

### Testing

#### Recommended Test Equipment

- 1 Power supply
- 2 Multimeter

#### Test Procedure

- 1 Make visual check that all mechanical parts are well placed and properly fixed

- together
- 2 Check that PHONE\_RECOGNIZING-line activate when BTEMP voltage is 0.17
- 3 Check FBUS / MBUS filters

## User Instructions

### General instruction

*NOTE: Be careful with pins. Especially if you change them or open the jig.*

### Operation

*Normal:*

- 1 Check that all pins and small pcb are OK.
- 2 Set MJF-1 to JBV-1 by pushing it's dowel pins to JBV-1 holes.
- 3 Best way to assemble a phone into jig is put the phone's battery spring side first to the jig and then other side.

### Over current and voltage

MJF-1 don't have over voltage or over current protection. All protection devices are in JBV-1.

## Assembly

### Construction

Figure 13: MJF-1 assembled with JBV-1

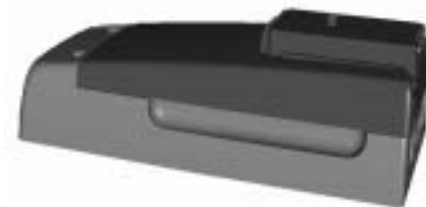

## Changing the test pins to MJF-1

Step 1. Opening the MJF-1 cover.

Open the screws using the TX6 chisel and open the MJF-1 cover with the chisel.

Figure 14: Opening the MFJ-1 cover.



Step 2. Take away the pwb 1

Open the screws by the chisel and take the pwb out of MJF-1.

Figure 15: Taking away the pwb 1



Step 3. Pulling the test pins out of pwb

Pull test pins from pwb 1 by using thin sharpness pliers.

*Note: Make sure you take hold of the right place on the test pins. Do not take hold of the lowest part of the test pins to avoid disturbing base of the test pins. The best place is the middle of the top location of the test pins. From here, it will be successful to change the pins.*

Figure 16: Pulling the test pins out of the pwb



Step 4. Adding the pwb into the MJF-1

Locate pwb 1 carefully to the MJF-1 focusing the right adjustment with the test pins. Push by using your finger the pwb 2 to the MJF-1's hole.

Figure 17: Adding the pwb into the MFJ-1



Step 5. Adding cover into MJF-1

Fasten screws using the TX6 chisel

## Flash Adapter FLA-14 0080538

### Introduction

Flash adapter FLA-14 is designed for regional Central Services and POS (Point of Sales) to replace phones own battery when flashing the phone. The FLA-14 contains three protections:

- Over current protection
- Over voltage protection
- Voltage polarity protection

### List of Modules

Table 10: List of modules

Name of modules	NMP type	NMP code	Notes
Flash adapter	FLA-14	0080538	Flash adapter to AMS usage

## Technical Specifications

### DC Characteristics

Table 11: Electrical ratings

Parameter	Min	Nom	Max	Notes
Input voltage (charger)	5.5V	-	16V	
Supply voltage (power supply)	3.0V	-	4.2V (16V *)	
Vbatt (charger)	3.8V	3.9V	4.1V	Regulated
Vbatt (power supply)	3.0V	-	4.2V	No regulation
Vbatt current (charger)	210mA	-	300mA	Rejected
Vbat protection current	2A			Resettable fuse
BTEMP Local mode Normal mode		560R 47k		Resistor
BSI Local mode Normal mode		560R 68k		Resistor

\*) Absolutely maximum value, do not exceed.

### Modes of operation

Flash adapter FLA-14 can be used in two operation modes:

- Normal mode (input voltage 3.0 – 4.2V)
- Local mode for flashing (input voltage 5.5 – 16V)

**Mechanical Characteristics**

Table 12: Mechanical characteristics

Unit	Dimensions (mm) (W x H x D)	Weight (g)	Material
FLA-14	45.5x32.8x76.4	75	ABS/PC, Cycoloy C1000F

Figure 18: Main dimensions of FLA-14

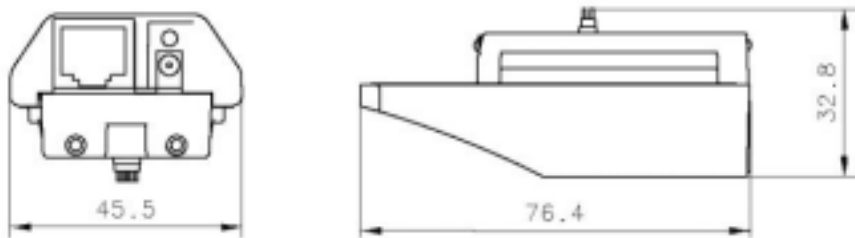

**Environmental Conditions**

**Temperature Conditions**

Table 13: Allowed ambient temperatures

	Ambient temperature (degrees Celcius)
Operating temperature	+5...+35
Storage temperature	-30...+60
Humidity RH	Max. 90%

**Functional Description**

**Circuit Description**

In Normal mode, when 3.0 – 4.2V supply voltage is used, the output voltage windowing circuit controls the FET-transistor V1, which passes 3.0 – 4.2V to the VBATT line. In Local mode, when using the 5.5 – 16V supply voltage, the regulator N1 is enabled and the 4.1V regulated voltage is leaded to the VBATT line. The current is limited in Local Mode to 210 – 300mA. Led D3 indicates the used operation mode. Yellow light for 3.0 – 4.2V and green for 4.1V regulated voltage. Two auto switches are accomplished by bipolar NPN transistors. Resistor values for BSI and BTEMP line in Local mode are 560 Ohms and in Normal mode 68 / 47 kOhms.

Flash adapter has an over current protection (resettable fuse). It activates when VBATT-line is over loaded. Operation will be normalized automatically after supply voltage is switched off or fault condition is removed.

**Testing**

**Recommended Test Equipment**

- 1 Power supply

- 2 Scope
- 3 Multimeter
- 4 DC current loads 1.5A and 300mA

### Test Procedure

- 1 Check visually that all mechanical parts are well placed and properly fixed together
- 2 Check that Vbatt-line is shut when supply voltage is less than 2.9 V
- 3 Check that Vbatt-line wakes up when supply voltage is 3.0 V  $\pm 2\%$
- 4 Check that the indicator led is yellow
- 5 Check that BSI resistance 68k
- 6 Check that BTEMP resistance is 47k
- 7 Check that Vbatt-line shuts down when supply voltage has risen up to 4.2 V  $\pm 2\%$
- 8 Check that Vbatt-line (4.1 V  $\pm 2\%$ ) wakes up when supply voltage is over 5.5V
- 9 Check that the indicator led is green
- 10 Check that BSI and BTEMP resistances are 560 Ohms
- 11 Check the current limitation; Vbatt-line shuts down when current is between 210– 350 mA (supply voltage 10 V)
- 12 Check that total resistance value in FBUS TX/RX filter lines is 940 $\Omega$   $\pm 1\%$
- 13 Check that total resistance value in MBUS filter line is 94 $\Omega$   $\pm 1\%$

### User Instructions

#### General instruction

*Note: Be careful with the pins, especially if you change them or open the jig.*

#### Operation

*Normal:*

- 1 Check that all pins and small pcb are OK.
- 2 Best way to assemble a phone into jig is put the phone's battery spring side first to the jig and then other side.

### Assembly

#### Construction

Figure 19: FLA-14 top view



### Changing the test pins to FLA-14

Step 1. Opening the FLA-Acover2

Open the FLA-Acover2 by using a chisel. Push the chisel carefully between FLA-Acover2 and FLA-Bcover. Open the FLA-Acover2 prising the chisel.

Figure 20: Opening the FLA-Acover2



Step 2. Taking pwb 1 out of front cover

Using the same chisel, push the pwb 2 down and pull using your other hand pwb1 rid of FLA-Bcover.

Step 3. Gripping pins from pcb 1

Pull test pins from pwb 1 by using thin sharpness pliers.

*Note: Make sure that you take hold of the right place on the test pins. Do not take hold of the lowest part of the test pins to avoid disturbing the base of the test pins. The best place is the middle of the top location of the test pins. This way, you will be successful in changing the pins.*

Step 4. Fastening the pcb to the FLA-Bcover

Locate pwb 1 carefully to the FLA-Bcover focusing the right adjustment with the test pins. Push the pwb 2 to the FLA-Bcover's hole with your finger. Push pwb 2 carefully vertical to the FLA-Bcover.

Figure 21: Fastening the pcb to the FLA-Bcover



Step 5. Fastening the FLA-Acover2 to the FLA-Bcover.

Pull carefully the FLA-Bcover in to the FLA-Acover2.

This page intentionally left blank.